

Exercise 2: Basic structural mechanics

25.10.2024 - 01.11.2024

This exercise deals with elementary concepts in structural mechanics. Below is a short reminder of common supports and joint types, which may be useful in this context.

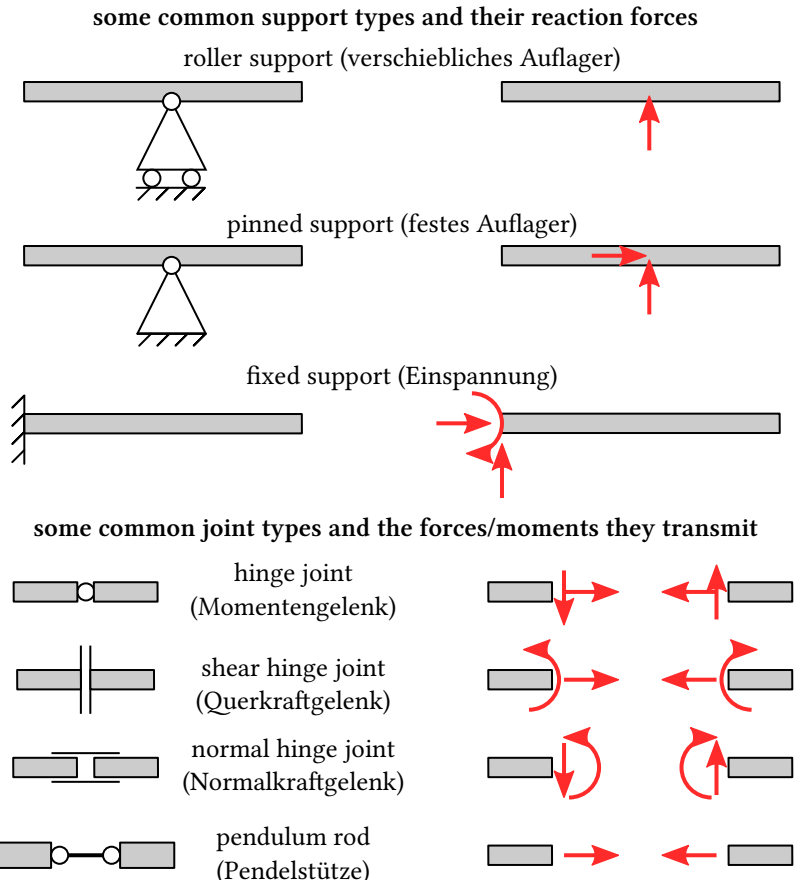

Recall that a 2D structure is statically determinate if

$$3n - (r + v) = 0,$$

where n is the number of bodies, r the number of reaction forces or moments of the supports, and v the number of forces or moments transmitted at links. If this sum is greater than zero, then the system has unconstrained degrees of freedom, i.e. it can move. If the sum is less than zero, then the system is statically indeterminate. Keep in mind degenerate cases, which were discussed in class!

Question 1
 Are the following systems statically determinate? Which of these are over- or underconstrained?

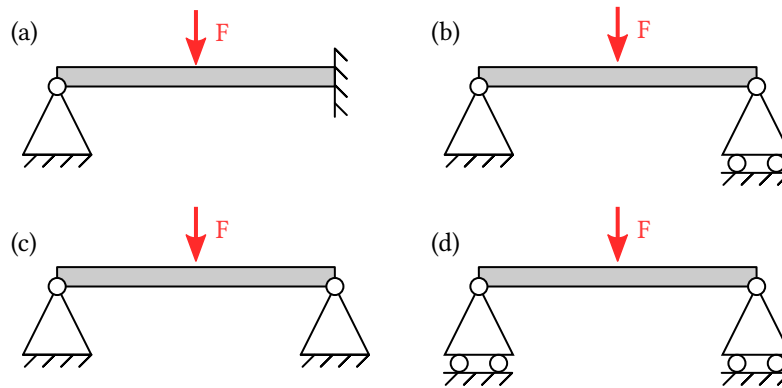

Solution:

(a) $n = 1, r = 5, v = 0 \quad 3 \times 1 - (5 + 0) = -2 \implies$ overconstrained

(b) $n = 1, r = 3, v = 0 \quad 3 \times 1 - (3 + 0) = 0 \implies$ statically determinate

(c) $n = 1, r = 4, v = 0 \quad 3 \times 1 - (4 + 0) = -1 \implies$ overconstrained

(d) $n = 1, r = 2, v = 0 \quad 3 \times 1 - (2 + 0) = 1 \implies$ underconstrained

Question 2
 For the structure below, calculate the reaction forces, as well as the internal forces and moments. Note that the positive y -direction points out of the plane of the paper.

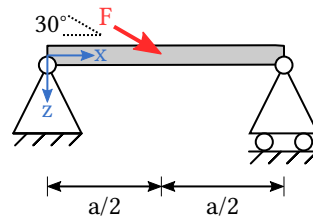

Solution: $n = 1, r = 3, v = 0, \quad 3 \times 1 - (3 + 0) = 0 \implies$ the structure is statically determinate. We will require equilibrium of the whole structure to determine the reaction forces:

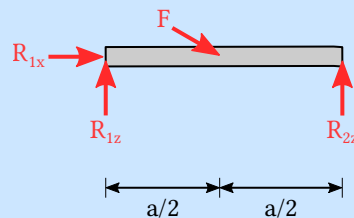

$$\begin{aligned} \rightarrow \quad R_{1x} + \frac{\sqrt{3}}{2}F &= 0 \quad \Rightarrow R_{1x} = -\frac{\sqrt{3}}{2}F \\ \uparrow \quad R_{1z} - \frac{1}{2}F + R_{2z} &= 0 \quad \Rightarrow R_{1z} = \frac{1}{2}F - R_{2z} \\ \textcircled{1} \quad -\frac{a}{2}\frac{1}{2}F + R_{2z}a &= 0 \quad \Rightarrow R_{2z} = \frac{1}{4}F \\ &\quad \Rightarrow R_{1z} = \frac{1}{4}F \end{aligned}$$

We will cut the bar left of the point where F is applied and require equilibrium for this section to determine the internal forces and moment there:

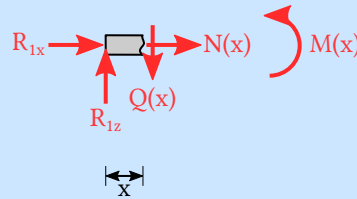

$$\begin{aligned} \rightarrow \quad R_{1x} + N(x) &= 0 \quad \Rightarrow N(x) = -R_{1x} = \frac{\sqrt{3}}{2}F \\ \uparrow \quad R_{1z} - Q(x) &= 0 \quad \Rightarrow Q(x) = R_{1z} = \frac{1}{4}F \\ \textcircled{S} \quad -R_{1z}x + M(x) &= 0 \quad \Rightarrow M(x) = R_{1z}x = \frac{x}{4}F \end{aligned}$$

We will cut the bar right of the point where F is applied and require equilibrium for this section to determine the internal forces and moment there:

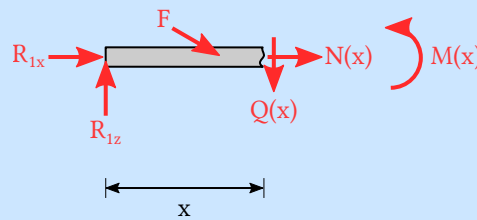

$$\begin{aligned} \rightarrow \quad R_{1x} + \frac{\sqrt{3}}{2}F + N(x) &= 0 \quad \Rightarrow N(x) = -R_{1x} - \frac{\sqrt{3}}{2}F = \frac{\sqrt{3}}{2}F - \frac{\sqrt{3}}{2}F = 0 \\ \uparrow \quad R_{1z} - \frac{1}{2}F - Q(x) &= 0 \quad \Rightarrow Q(x) = R_{1z} - \frac{1}{2}F = -\frac{1}{4}F \\ \textcircled{S} \quad -R_{1z}x + \frac{1}{2}F\left(x - \frac{a}{2}\right) + M(x) &= 0 \quad \Rightarrow M(x) = R_{1z}x - \frac{1}{2}F\left(x - \frac{a}{2}\right) = -\frac{1}{4}(x - a)F \end{aligned}$$

Note that $M(x = a) = 0$, as we would expect.

Question 3

Check whether the following systems are statically determinate! Note that they contain hinges.

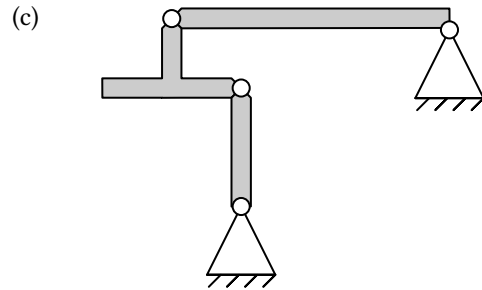
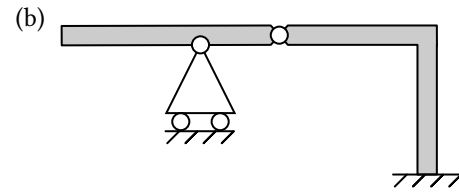
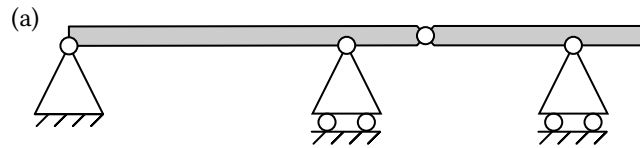

Solution:

(a) $n = 2, r = 4, v = 2 \quad 3 \times 2 - (4 + 2) = 0 \implies$ statically determinate

(b) $n = 2, r = 4, v = 2 \quad 3 \times 2 - (4 + 2) = 0 \implies$ statically determinate

(c) $n = 3, r = 4, v = 4 \quad 3 \times 3 - (4 + 4) = 1 \implies$ underconstrained

Question 4

For the two problems below you should (i) check whether they are statically determinate, and (ii) calculate the reaction forces at the supports. Use the indicated coordinate system (blue)! Note that the positive y -direction points out of the plane of the paper. *Hint:* problem (b) is slightly more complicated than (a) because here the structure consists of two bars, not one. Cut the structure at the hinge G, and write the equilibrium conditions for the bars A-G and B-G separately. Don't forget the two forces that are transmitted at the hinge when you make the cut! You can afterwards check your solution by considering the equilibrium conditions for the complete structure.

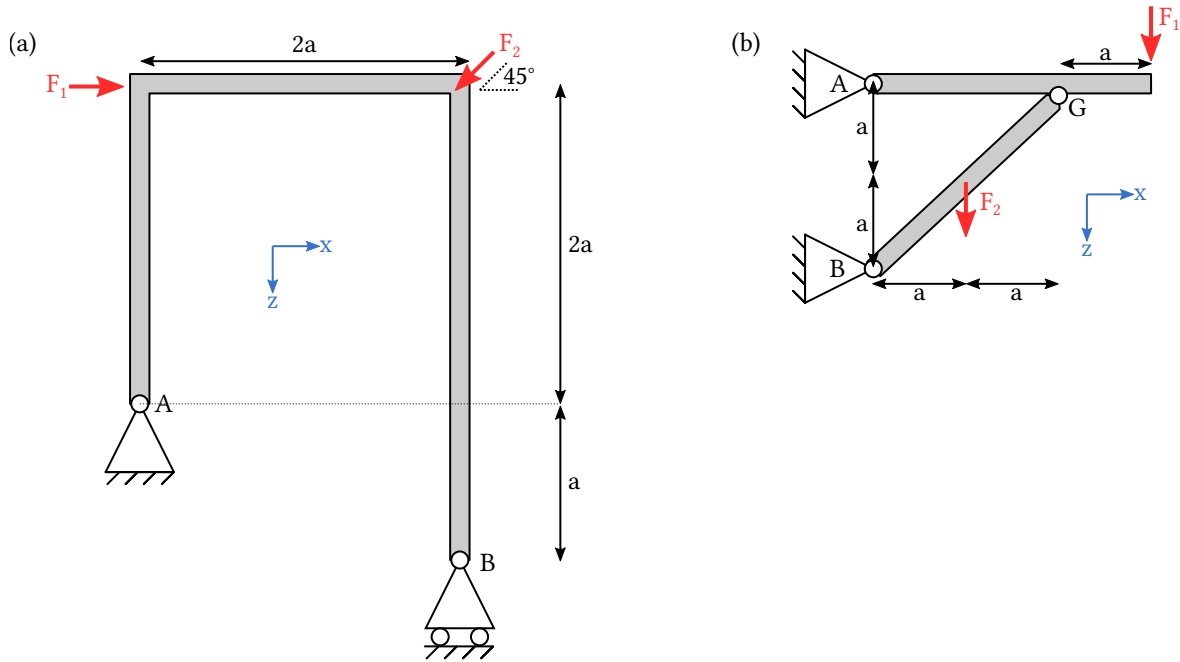

Solution:

a) *Reference:* this exercise was adapted from: Gross, Ehlers, Wriggers, Schröder, Müller, Formeln und Aufgaben zur technischen Mechanik 1, 12th edition, Springer Verlag (page 57).

$n = 1, r = 3, v = 0, \quad 3 \times 1 - (3 + 0) = 0 \implies$ statically determinate. We will require equilibrium of the whole structure to determine the reaction forces. Note that the line of action of F_2 goes through bearing A. Moreover, keep in mind that $\cos(45^\circ) = \sin(45^\circ) = 1/\sqrt{2}$.

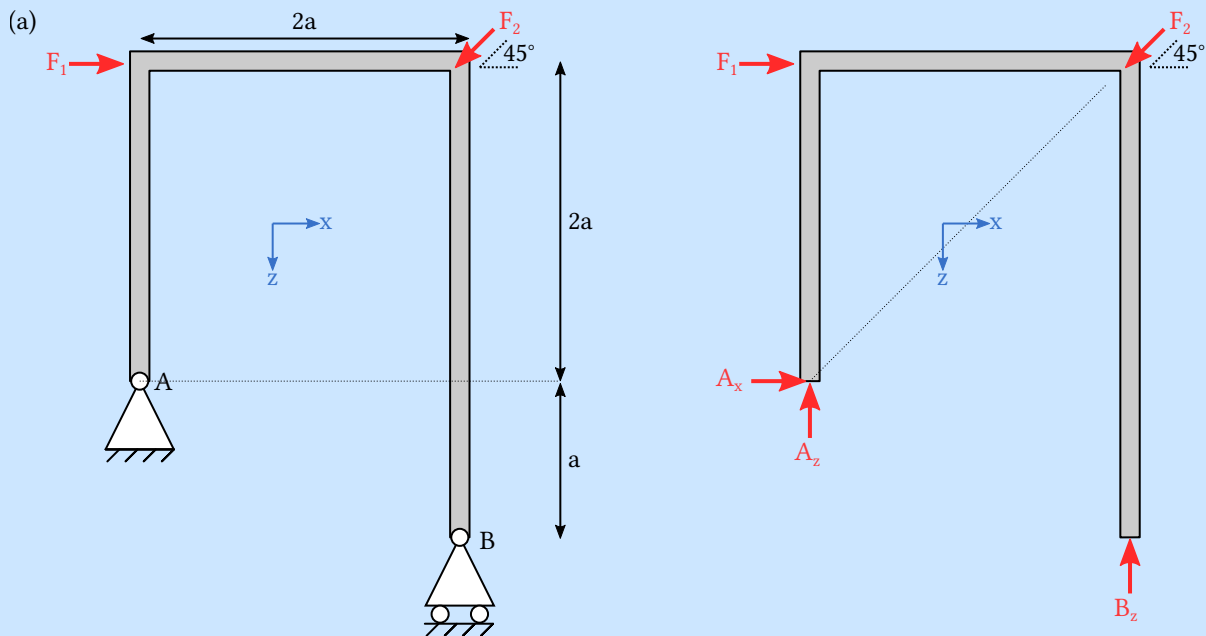

$$\begin{aligned} \textcircled{A} \quad 2aB_z - 2aF_1 &= 0 \quad \implies B = F_1 \\ \uparrow \quad A_z + B - F_2 \frac{1}{\sqrt{2}} &= 0 \quad \implies A_z = F_2 \frac{1}{\sqrt{2}} - F_1 \\ \rightarrow \quad A_x + F_1 - F_2 \frac{1}{\sqrt{2}} &= 0 \quad \implies A_x = F_2 \frac{1}{\sqrt{2}} - F_1 \end{aligned}$$

b) *Reference:* this exercise was adapted from: Gross, Hauger, Schröder, Wall, Technische Mechanik 1, 13th edition, Springer Verlag (page 138).

$n = 2, r = 4, v = 2, \quad 3 \times 2 - (4 + 2) = 0 \implies$ the structure is statically determinate. We will cut the structure at the hinge and require equilibrium for each of the two bars.

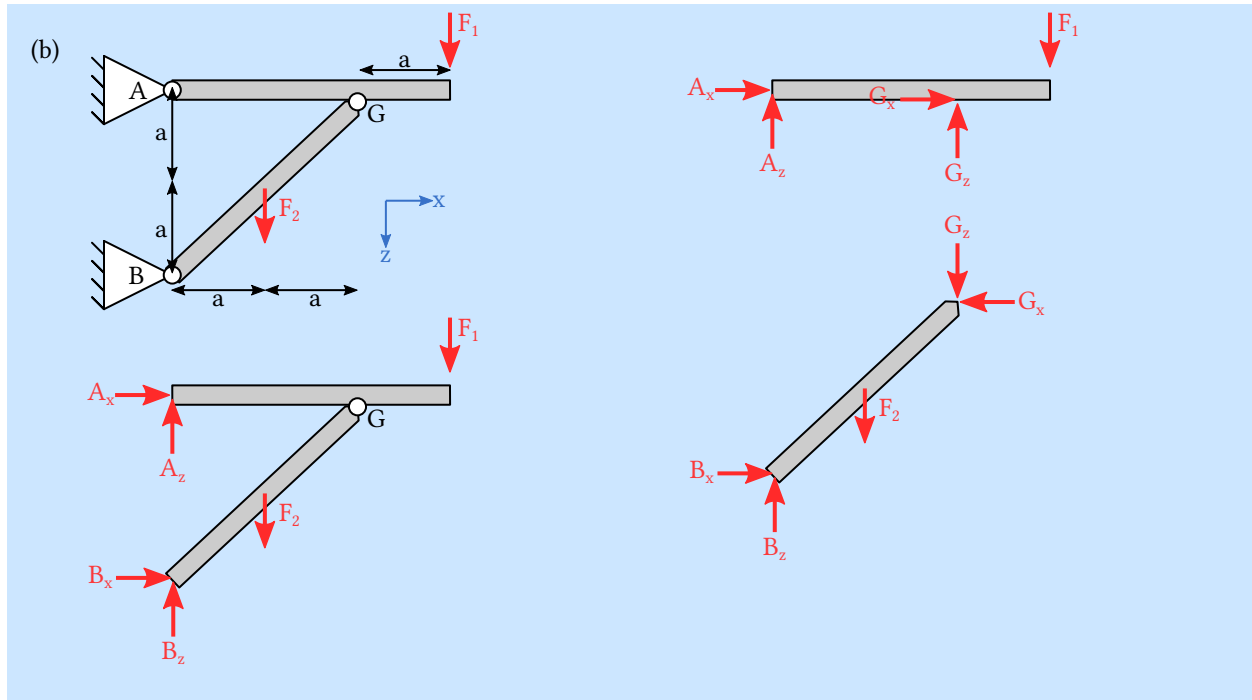

First, consider the horizontal bar.

$$\textcircled{A} \quad 2aG_z - 3aF_1 = 0 \implies G_z = \frac{3}{2}F_1,$$

$$\textcircled{G} \quad -2aA_z - aF_1 = 0 \implies A_z = -\frac{1}{2}F_1,$$

$$\rightarrow A_x + G_x = 0.$$

For the other bar, we find

$$\textcircled{B} \quad -aF_2 - 2aG_z + 2aG_x = 0 \implies G_x = \frac{1}{2}F_2 + G_z = \frac{1}{2}(3F_1 + F_2)$$

$$\rightarrow B_x - G_x = 0 \implies B_x = G_x = \frac{1}{2}(3F_1 + F_2),$$

$$\textcircled{G} \quad 2aB_x - 2aB_z + aF_2 = 0 \implies B_z = \frac{1}{2}F_2 + B_x = \frac{3}{2}F_1 + F_2.$$

Question 5
 Sketched below is a GERBER girder. Check that the problem is statically determinate, calculate the reaction forces and finally calculate the internal forces and moments. Use the indicated coordinate system (blue)! Note that the positive y -direction points out of the plane of the paper. *Hint:* like in question 4(b) you can determine all reaction forces only if you consider equilibrium conditions separately for the two bars.

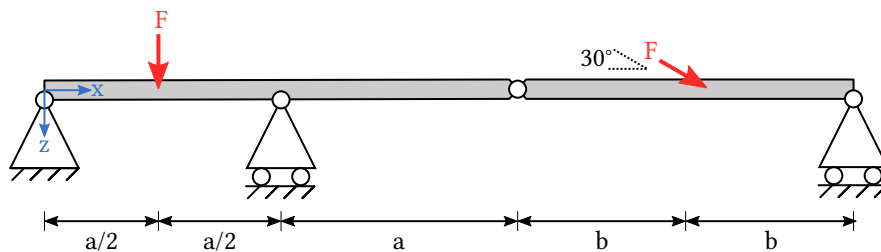

Solution: $n = 2, r = 4, v = 2, 3 \times 2 - (4 + 2) = 0 \implies$ the structure is statically determinate. We will cut the girder at the hinge and require equilibrium for each of the two bars. Keep in mind that $\sin(30^\circ) = 1/2$ and $\cos(30^\circ) = \sqrt{3}/2$.

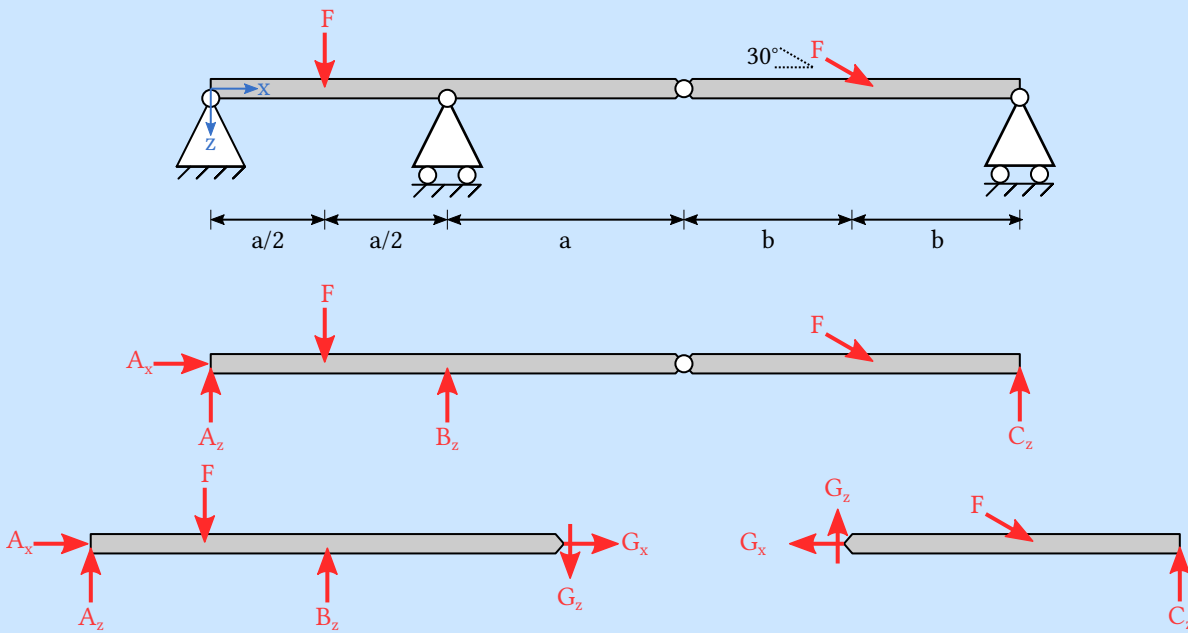

Let us start with the bar on the right, because there is only one reaction force.

$$\begin{aligned} \rightarrow \quad & -G_x + \frac{\sqrt{3}}{2}F = 0, \implies G_x = \frac{\sqrt{3}}{2}F, \\ \textcircled{F} \quad & -G_z b + C_z b = 0 \implies C_z = G_z, \\ \uparrow \quad & G_z - \frac{1}{2}F + C_z = 0 \implies C_z = G_z = \frac{1}{4}F. \end{aligned}$$

Here \textcircled{F} indicates the moment about the point where F is applied.

For the left bar we find

$$\begin{aligned} \rightarrow \quad & A_x + G_x = 0 \implies A_x = -G_x = -\frac{\sqrt{3}}{2}F \\ \textcircled{A} \quad & -F \frac{a}{2} + B_z a - G_z 2a = 0 \implies B_z = \frac{1}{2}F + G_z 2 = F, \\ \uparrow \quad & A_z - F + B_z - G_z = 0 \implies A_z = F - B_z + G_z = \frac{1}{4}F. \end{aligned}$$

We can check this solution by requiring equilibrium of the *whole* structure:

$$\begin{aligned} \rightarrow \quad & A_x + \frac{\sqrt{3}}{2}F = 0 \implies \frac{\sqrt{3}}{2}F - \frac{\sqrt{3}}{2}F = 0 \quad \text{OK!} \\ \uparrow \quad & A_z + B_z + C_z - F - \frac{1}{2}F = 0 \implies \frac{1}{4}F + F + \frac{1}{4}F - F - \frac{1}{2}F = 0 \quad \text{OK!} \end{aligned}$$

Now we can determine the internal forces. We need to make five cuts. It is convenient to consider the right side of the cut in case of the right bar.

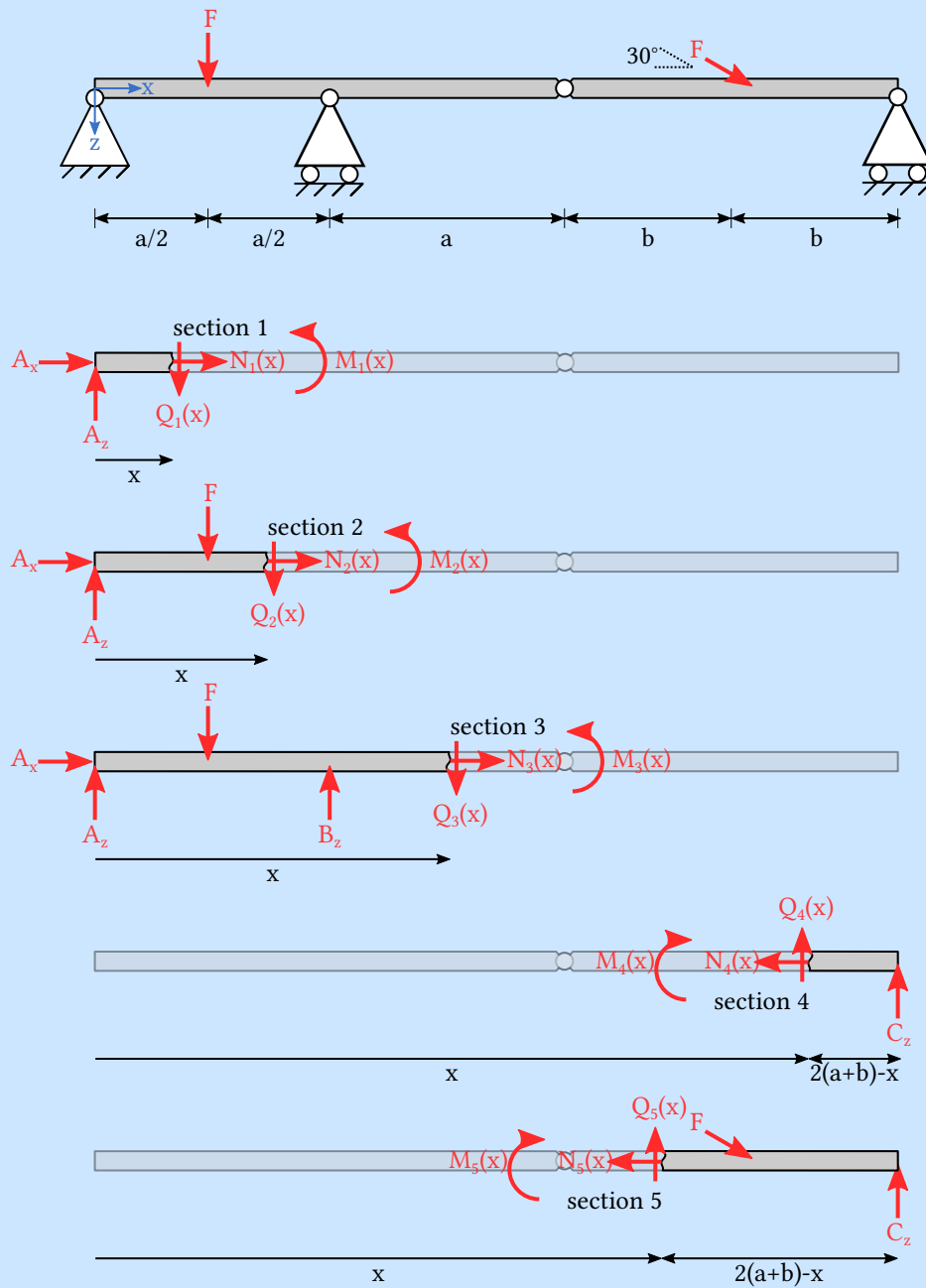

By requiring equilibrium for section 1, we get

$$\begin{aligned} \rightarrow \quad N_1(x) + A_x &= 0 & \implies N_1(x) &= -A_x = \frac{\sqrt{3}}{2}F, \\ \uparrow \quad A_z - Q_1(x) &= 0 & \implies Q_1(x) &= A_z = \frac{1}{4}F, \\ \textcircled{S1} \quad -A_z x + M_1(x) &= 0 & \implies M_1(x) &= A_z x = \frac{1}{4}Fx. \end{aligned}$$

Here \curvearrowright (S1) indicates that we take the moment about the point of the cut.

In section 2

$$\begin{aligned} \rightarrow \quad N_2(x) + A_x &= 0 & \implies N_2(x) = -A_x = \frac{\sqrt{3}}{2}F, \\ \uparrow \quad A_z - Q_2(x) - F &= 0 & \implies Q_2(x) = A_z - F = -\frac{3}{4}F, \\ \curvearrowright \text{ (S2)} \quad -A_z x + F \left(x - \frac{1}{2}a\right) + M_2(x) &= 0 & \implies M_2(x) = A_z x - F \left(x - \frac{1}{2}a\right) = -\frac{3}{4}Fx + \frac{1}{2}Fa. \end{aligned}$$

In section 3

$$\begin{aligned} \rightarrow \quad N_3(x) + A_x &= 0 & \implies N_3(x) = -A_x = \frac{\sqrt{3}}{2}F, \\ \uparrow \quad A_z - Q_3(x) - F + B_z &= 0 & \implies Q_3(x) = A_z - F + B_z = \frac{1}{4}F, \\ \curvearrowright \text{ (S3)} \quad -A_z x + F \left(x - \frac{1}{2}a\right) - B_z(x - a) + M_3(x) &= 0 \\ \implies M_3(x) = A_z x - F \left(x - \frac{1}{2}a\right) + B_z(x - a) &= \frac{1}{4}Fx - \frac{1}{2}Fa. \end{aligned}$$

Note that the moment goes to zero at the hinge where $x = 2a$.

In section 4

$$\begin{aligned} \rightarrow \quad N_4(x) &= 0, \\ \uparrow \quad C_z + Q_4(x) &= 0 & \implies Q_4(x) = -C_z = -\frac{1}{4}F, \\ \curvearrowright \text{ (S4)} \quad C_z(2(a+b) - x) - M_4(x) &= 0 & \implies M_4(x) = \frac{1}{4}F(2(a+b) - x). \end{aligned}$$

In section 5

$$\begin{aligned} \rightarrow \quad -N_5(x) + \frac{\sqrt{3}}{2}F &= 0 & \implies N_5(x) = \frac{\sqrt{3}}{2}F, \\ \uparrow \quad Q_5(x) - \frac{1}{2}F + C_z &= 0 & \implies Q_5(x) = \frac{1}{4}F, \\ \curvearrowright \text{ (S5)} \quad -M_5(x) - \frac{1}{2}F(2a+b-x) + C_z(2(a+b) - x) &= 0 \\ \implies M_5(x) = -\frac{1}{2}Fa + \frac{1}{4}Fx. \end{aligned}$$

Note that the internal forces in section 3 match those in section 5 at the position of the hinge ($x = 2a$).